

HAND PALLET JACK



SMOOTH MOVES

- ▶ Up to 8000 Lb. Capacity
- ▶ Various Fork Sizes
- ▶ Low/Ultra-Low Profile & 4-Way Entry Options
- ▶ Electric Lift & Freezer Galvanized Options



HPT28U

SIMPLY MORE PRODUCTIVE

THE TOYOTA HAND PALLET JACK. Anchored by our most popular and versatile HPT28U model, Toyota Hand Pallet Jacks make light work of moving product through your warehouse or distribution center. Our workhorse HPT28U is supplemented with several additional models, for specific industries and applications. All models feature low rolling resistance, low noise levels and ergonomic design advantages like large handgrips and a 3-position handle. As well as complete warranties covering hydraulic pumps, frames, chasses and wearable components.

HAND PALLET JACK ADVANTAGES

- ▶ **DURABLE CONSTRUCTION** to withstand significant wear and tear
- ▶ **ROLL-FORMED STEEL FRAME** for maximum strength
- ▶ **HEAVY-DUTY SOLID NYLON LOAD WHEELS & STEER WHEELS** with entry/exit rollers for low rolling resistance and smoother handling
- ▶ **RELIABLE ONE-PIECE HYDRAULIC PUMP** with leak-proof cast iron pump body
- ▶ **HEAVY-DUTY BALL-TYPE THRUST BEARING** for easy steering and long-term reliability
- ▶ **LARGE ERGONOMIC GRIP & 3-POSITION HANDLE WITH NEUTRAL POSITION** enhance operator comfort and help reduce fatigue for increased productivity
- ▶ **ELECTRIC ERGONOMIC** load positioning and lifting (Model RG30E)
- ▶ **GALVANIZED FRAME** for freezer/refrigerated applications (Model LCF55)
- ▶ **LOW/ULTRA-LOW PROFILE** for pallets or skids with low clearance openings (Models LCM50/LCU50, LCM4W/LCU4W)



UP TO

8000 LB.

CAPACITY

VARIOUS
FORK SIZES

RUGGED &
LIGHTWEIGHT

▶ **4-WAY ENTRY/LOW PROFILE** for easy handling of 4-way entry pallets (Model LCM4W/LCU4W)

▶ **INDUSTRY-LEADING WARRANTIES** covering all major parts and wearable components



HAND PALLET JACK

CAPACITY
5500 LBS.

LOAD CENTER
24 IN.

TRUCK WEIGHT
167 LBS.

INDUSTRIES



Beverage



Cold Storage



Food Storage



Forging & Casting



General Manufacturing



General Warehousing



Retail

BASE MODEL: HPT28U

Our most versatile, best selling hand pallet jack, our HPT28U is anything but basic — with industry-leading features that make operators more productive and less fatigued.

STANDARD FEATURES

- Curvilinear handle
- 180° steering arc
- Easy-to-operate controls
- Neutral position
- Strong handle return spring
- Tow bar shoulder support
- 3" lowered height
- Low-profile, lightweight design
- Variable speed lowering
- Powder-coated Toyota orange paint
- High-tensile strength steel frame
- Profiled forks with single load wheel & entry/exit rollers
- One-piece cast pump body with heavy-duty thrust ball bearing
- Adjustable push bars
- Low noise levels & rolling resistance
- 10 grease fittings

OPTIONAL EQUIPMENT

- Various fork widths (20.5," 27")
- Various fork lengths (36," 42," 48")
- White nylon, polyurethane or steel load & steer wheels
- 48" load backrest
- Quick-lift pump model
- Parking brake
- Power assist model (5000 lb. capacity)
- Stainless steel model (4400 lb. capacity)

WARRANTY

- Hydraulic pump: 2 years
- Frame: 1 year
- Wearable items: 6 months

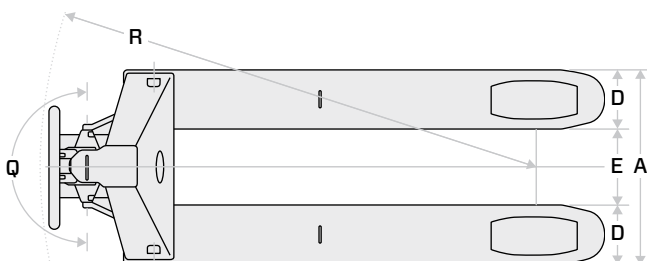

TRUCK SPECIFICATIONS

GENERAL DATA			HPT28U
Load Capacity		lb (kg)	5500 (2495)
Tire Type	Drive / Load		Nylon, Polyurethane or Steel
EXTERIOR DIMENSIONS			HPT28U
A	Overall Width	in (mm)	27 (685)
B	Fork Length	in (mm)	48 (1220)
C	Overall Length	in (mm)	62.6 (1590)
D	Fork Width	in (mm)	6.3 (160)
E	Width Between Forks	in (mm)	14.4 (365)
F	Lowered Height	in (mm)	3 (76.2)
G	Raised Height	in (mm)	7.75 (197)
H	Chassis Height (lowered)	in (mm)	17.6 (447)
I	Handle Height	in (mm)	48 (1220)
J	A-Frame to Steer Wheel Center	in (mm)	9.1 (230)
K	Front-End Length	in (mm)	14.6 (371)
L	Underclearance (lowered)	in (mm)	1.2 (30)
M	A-Frame to Load Wheel (lowered)	in (mm)	43.5 (1105)
N	A-Frame to Load Wheel (raised)	in (mm)	41.9 (1065)
O	Fork Tip to Assembly Pivot Point	in (mm)	10.6 (270)
P	Fork Tip to Load Wheel (lowered)	in (mm)	4.5 (115)
Q	Steering Arc	deg	180
R	Turning Radius	in (mm)	57.1 (1452)
S	Fork Tip to Load Wheel (raised)	in (mm)	6.1 (155)
TIRES			HPT28U
Dual Steer Wheels	Diameter x Width	in (mm)	6.9 x 2.4 (175 x 60)
Dual Load Wheels	Diameter x Width	in (mm)	2.9 x 3.9 (75 x 100)
WEIGHT			HPT28U
Total Weight		lb (kg)	167 (76)

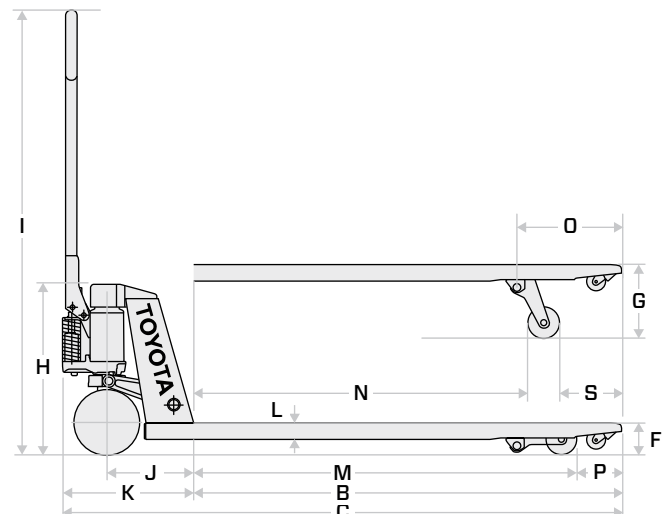

UNIQUE SIZE: LCS55

The Unique Size series truck is assigned for special size applications requiring a robust 5500 pound evenly distributed load capacity.

STANDARD FEATURES

- Reinforced fork design provides strength & rigidity required for custom length pallets/skids
- High-quality solid nylon wheels & rollers prevent premature failure associated with bonded wheels material
- One-piece cast hydraulic pump provides maintenance-free performance & superior lowering control of larger/heavy loads
- Durable powder-coated finish to keep that new truck look longer

WARRANTY

- Hydraulic pump: 2 years
- Frame: 1 year
- Wearable items: 6 months

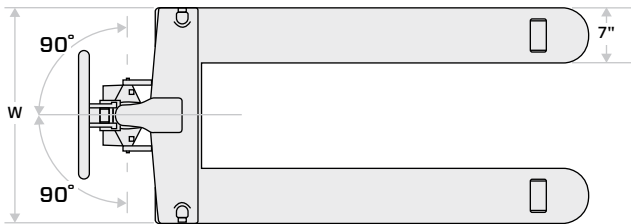

TRUCK SPECIFICATIONS

GENERAL DATA	MODEL NUMBER	
	LCS55	
Load Capacity	lb (kg)	5500 (2495)
Fork Frame Width	in (mm)	18(i), 20.5(ii), 27(iii)
Fork Length	in (mm)	36(i), 60(iii), 72(ii, iii), 96 (iii)
Fork Height (lowered / raised)	in (mm)	3 / 7.875 (83 / 800)
Weight	lb (kg)	Consult Factory
Steer Wheel (dia. x width)	in (mm)	7 x 2.375 (178 x 60)
Load Roller (dia. x width)	in (mm)	3 x 4 (76 x 102)

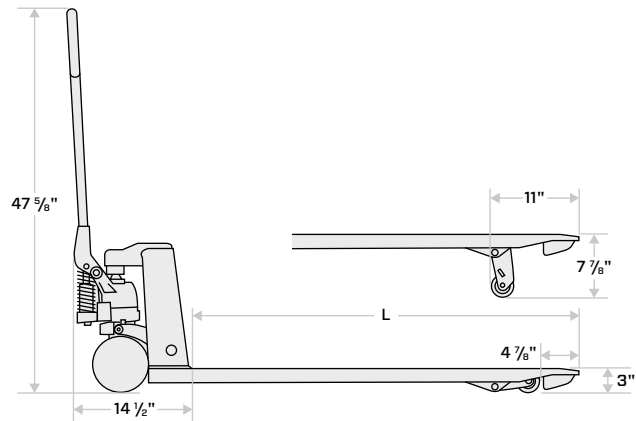

LOW/ULTRA-LOW PROFILE: LCM50/LCU50

The Low and Ultra-Low Profile series trucks feature lowered fork heights necessary to handle pallets or skids with low clearance openings, while maintaining an impressive 5000 pound maximum load capacity.

STANDARD FEATURES

- Low-profile formed forks suitable for pallets or skids with low clearance openings
- One-piece, leak-proof cast hydraulic pump
- High-quality powder-coated finish

WARRANTY

- Hydraulic pump: 2 years
- Frame: 1 year
- Wearable items: 6 months

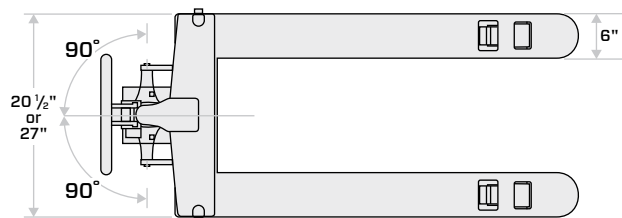

TRUCK SPECIFICATIONS

GENERAL DATA	MODEL NUMBER	
	LCM50	LCU50
Load Capacity	lb (kg)	5000 (2268)
Fork Frame Width (A)	in (mm)	20.5 (521) 27 (686)
Fork Length (L)	in (mm)	48 (1219)
Fork Height (lowered / raised)	in (mm)	2 / 6.75 (51 / 171) 1.75 / 6.6 (44 / 168)
Weight (27 x 48 size)	lb (kg)	175 (79)
Steer Wheel (dia. x width)	in (mm)	7 x 2.375 (178 x 60)
Load Roller (dia.)	in (mm)	2 (51) 1.75 (44)

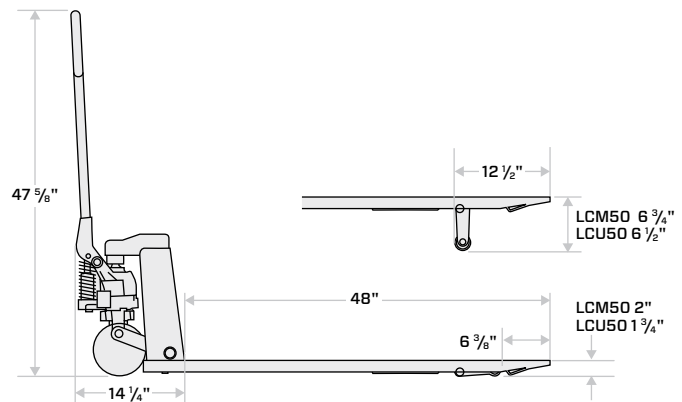

4-WAY ENTRY/LOW PROFILE: LCM4W/LCU4W

The 4-Way hand pallet trucks allow the operator to easily handle four way-entry pallets in all four directions, offering for maximized warehouse space and trailer load density.

STANDARD FEATURES

- Low-profile formed forks suitable for pallets or skids with low clearance openings
- One-piece, leak-proof cast hydraulic pump
- High-quality powder-coated finish
- Frame size optimized for 4-way pallets

WARRANTY

- Hydraulic pump: 2 years
- Frame: 1 year
- Wearable items: 6 months

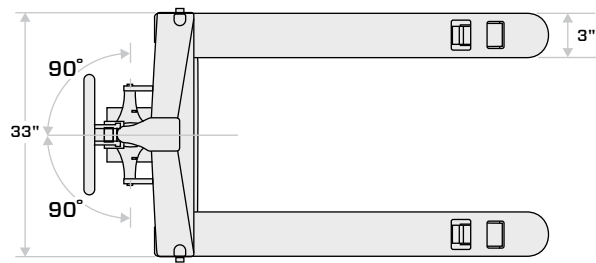

TRUCK SPECIFICATIONS

GENERAL DATA	MODEL NUMBER	
	LCM4W	LCU4W
Load Capacity	lb (kg)	5000 (2268)
Fork Frame Width	in (mm)	33 (838)
Fork Length (L)	in (mm)	48 (1219)
Fork Height (lowered / raised)	in (mm)	2 / 6.75 (51 / 171) 1.75 / 6.6 (44 / 168)
Weight	lb (kg)	205 (93)
Steer Wheel (dia. x width)	in (mm)	7 x 2.375 (178 x 60)
Load Roller (dia.)	in (mm)	2 (51) 1.75 (44)

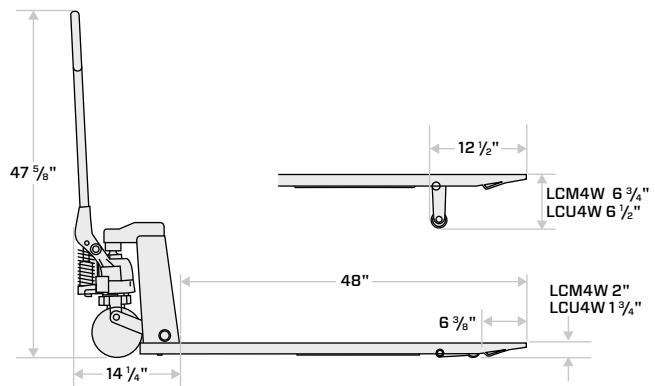

HEAVY-DUTY LOAD CAPACITY: LCS80

The Heavy-Duty Load Capacity truck's extra-strength hydraulics, chassis and forks suit it for the demands of manufacturing, commercial movers and military applications.

STANDARD FEATURES

- Suitable for high load capacity
- Heavy-duty hydraulic pump
- Heavy-duty chassis with structural channel forks
- Solid steel wheels & rollers

WARRANTY

- Hydraulic pump: 6 months
- Chassis: 6 months
- Wearable items: 6 months

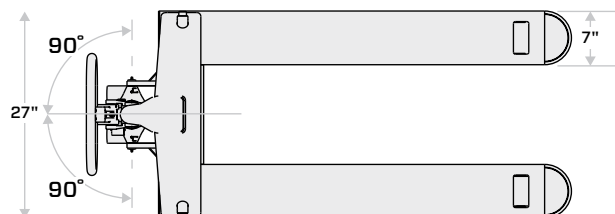

TRUCK SPECIFICATIONS

GENERAL DATA	MODEL NUMBER	
	LCS80	
Load Capacity	lb (kg)	8000 (3629)
Fork Frame Width	in (mm)	27 (686)
Fork Length (L)	in (mm)	48 (1219)
Fork Height (lowered / raised)	in (mm)	3.25 / 8 (82 / 203)
Weight	lb (kg)	305 (138)
Steer Wheel (dia. x width)	in (mm)	7 x 2.25 (178 x 57)
Load Roller (dia.)	in (mm)	3 (76)

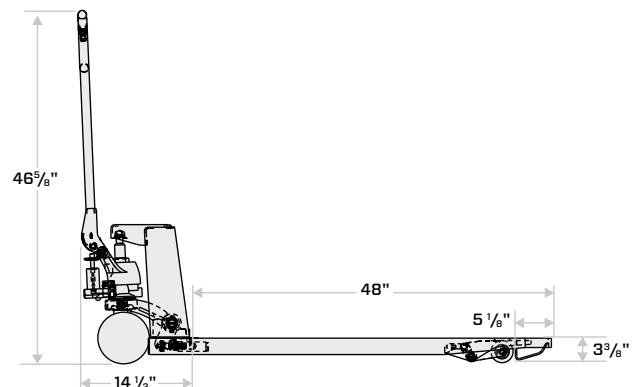

FREEZER SPECIAL: LCF55

The Freezer Special hand pallet truck resists the harsh effects of cold temperature. The exterior product treatment provides resistance to corrosion due to condensation associated with freezer and refrigeration applications.

STANDARD FEATURES

- Resistance to corrosion caused by condensation through various material & surface treatments
- Low-temperature hydraulic oil prevents hydraulic freeze-up and sluggish lifting/lowering
- Solid nylon wheels & rollers prevent premature failure associated with bonded wheels material in cold temperatures
- Hot-dip galvanized fork frame provides resistance to abrasion and premature surface treatment wear

WARRANTY

- Hydraulic pump: 6 months
- Chassis: 6 months
- Wearable items: 6 months

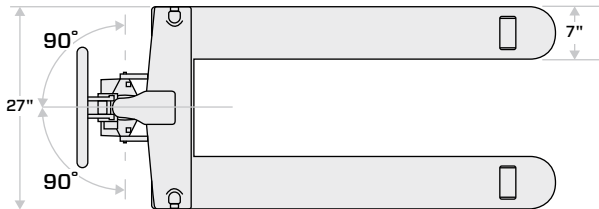

TRUCK SPECIFICATIONS

GENERAL DATA		MODEL NUMBER
Load Capacity	lb (kg)	5500 (2495)
Fork Frame Profile (width x length)	in (mm)	27 x 48 (686 x 1219)
Fork Height (lowered / raised)	in (mm)	3 / 7.875 (83 / 800)
Weight	lb (kg)	175 (79)
Steer Wheel (diameter x width)	in (mm)	7 x 2.375 (178 x 60)
Load Roller (diameter x width)	in (mm)	3 x 4 (76 x 102)

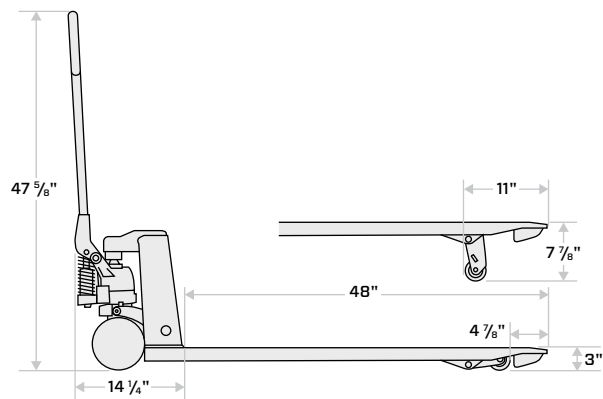

COMPLETE STAINLESS STEEL: HPT-SS

The Complete Stainless Steel truck's high-level corrosion resistance allows it to be completely washed down, making a good choice for pharmaceutical, fisheries and meat packing applications.

STANDARD FEATURES

- Stainless steel fork frame
- Stainless steel hydraulic pump
- Glass-blasted frame finish for easy cleaning

WARRANTY

- Hydraulic pump: 1 year
- Frame: 1 year
- Wearable items: 6 months

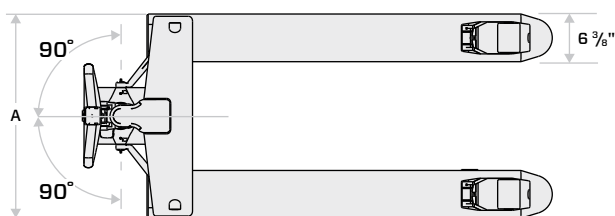

TRUCK SPECIFICATIONS

GENERAL DATA		MODEL NUMBER
Load Capacity	lb (kg)	4400 (1996)
Fork Frame Width	in (mm)	27 (686)
Fork Length	in (mm)	48 (1219)
Fork Height (lowered / raised)	in (mm)	3 / 7.75 (83 / 197)
Weight	lb (kg)	155 (70)
Steer Wheel (dia. x width)	in (mm)	7 x 2.25 (178 x 57)
Load Roller (dia.)	in (mm)	3 (76)

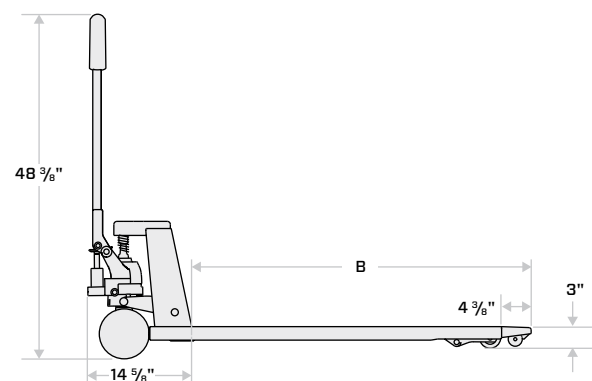

START-ASSIST: HPT25-PA

The Start Assist truck reduces the amount of operator effort and force needed to start or move a load manually, which can lead to increased operator productivity in retail, warehousing, shipping/receiving and manufacturing applications.

STANDARD FEATURES

- A pump of the handle propels the load forward
- Can also reverse by pumping the handle
- Powerthane drive wheels provide extra traction and can handle high-capacity loads

WARRANTY

- Hydraulic pump: 2 years
- Chassis: 2 years
- Power-Start mechanism: 1 year
- Wearable items: 6 months

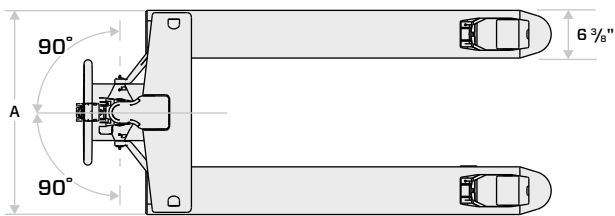

TRUCK SPECIFICATIONS

		MODEL NUMBER
GENERAL DATA		HPT25-PA
Load Capacity	lb (kg)	5000 (2268)
Fork Frame Width	in (mm)	27 (686)
Fork Length	in (mm)	36 / 42 / 48 (914 / 1067 / 1219)
Fork Height (lowered)	in (mm)	2.9 (74)
Weight	lb (kg)	188 (85)
Steer Wheel (diameter x width)	in (mm)	7 x 1.94 (178 x 49)
Load Roller (diameter)	in (mm)	3 (76)

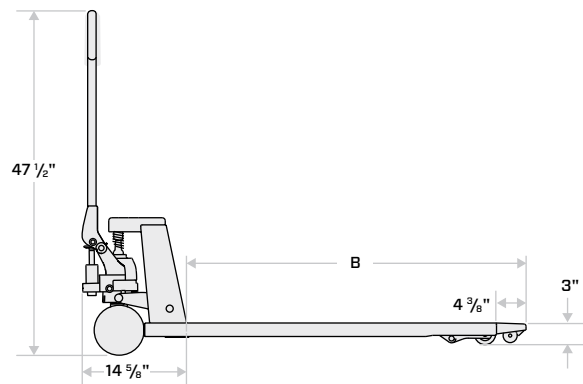

MOTORIZED DRIVE HPT: PST+

The Motorized Drive HPT truck utilizes clean electric power to allow for easy light-duty pallet movement and maneuverability in sensitive environments, such as hospitals and institutions, as well as retail stores.

STANDARD FEATURES

- 24V DC power drive unit
- 2 X 12V DC batteries
- Onboard automatic charger
- Powerthane drive tire

WARRANTY

- Hydraulic pump: 1 year
- Chassis: 1 year
- Wearable items: 6 months

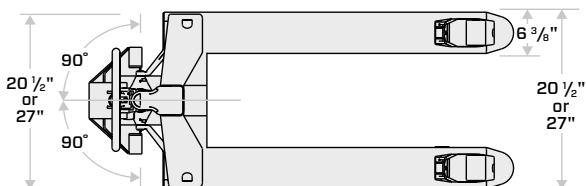

TRUCK SPECIFICATIONS

		MODEL NUMBER
GENERAL DATA		PST+
Load Capacity (marginal grade)	lb (kg)	2200 (998)
Fork Frame Width	in (mm)	20.5 or 27 (521 or 686)
Fork Length (L)	in (mm)	36 / 42 / 48 (914 / 1067 / 1219)
Fork Height (lowered / raised)	in (mm)	3 / 7.75 (76 / 197)
Weight	lb (kg)	235 (107)
Steer Wheel (dia. x width)	in (mm)	7 x 1.94 (178 x 49)
Load Roller (dia.)	in (mm)	3 (76)

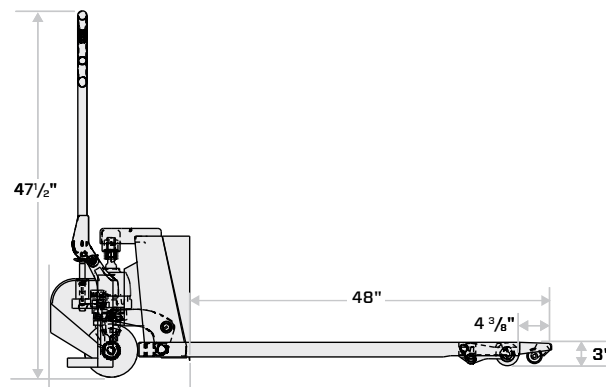

PORTABLE SKID LIFTER: RG30

The RG30 truck provides load positioning and lifting solutions in a portable configuration. This unit is available in manual or electric lift configurations, and is compatible with open bottom pallets/skids and containers only.

STANDARD FEATURES

- Solid steel scissor legs provide maximum strength & rigidity under load
- Manual lift pump comes complete with quick-lift feature to reduce pump strokes (Manual & Electric models)
- Push-button operated electric lift (Electric model)
- Maneuverable in lowered position & during first one-third of lift travel, then locks itself in place to remain stationary
- Complete with deep-cycle battery & built-in charger (Electric model)

WARRANTY

- Hydraulic pump: 1 year
- Chassis: 1 year
- Wearable items: 6 months

TRUCK SPECIFICATIONS

GENERAL DATA		MODEL NUMBER
Load Capacity	lb (kg)	3000 (1360)
Fork Frame Profile (width x length)	in (mm)	20.5 or 27 x 48 (521 or 686 x 1219)
Fork Height (lowered / raised)	in (mm)	3.25 / 31.5 (83 / 800)
Weight	Manual	340 (154)
	Electric	440 (200)
Steer Wheel (dia. x width)	in (mm)	8 x 2 (203 x 51)
Load Roller (dia. x width)	in (mm)	3 x 4 (76 x 102)

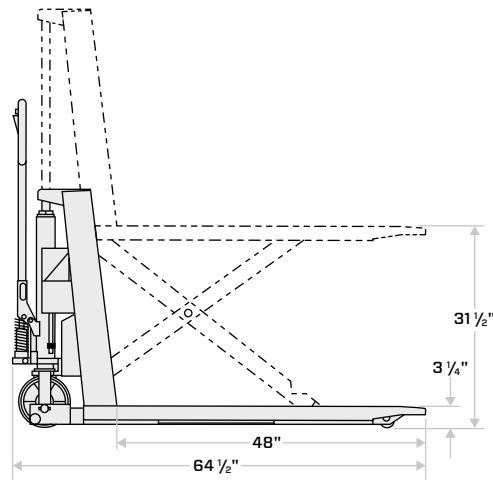
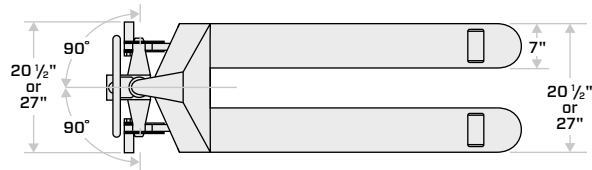





Stack of boxes with labels: DORMER LIGHT TANK & WATER, DORMER, MC-US GNA-1

Stack of boxes with labels: DORMER LIGHT TANK & WATER, DORMER

124
113

MC-US GNA-1



COUNT ON THE LEADER

- ▶ Toyota leads in quality, durability, reliability and value, thanks to advanced technology and the world-renowned Toyota Production System.
- ▶ With the broadest and most complete set of material-handling solutions in the industry, Toyota Dealers specialize in meeting all of your needs — from a single forklift to an entire fleet.
- ▶ Toyota's industry-leading network of dealers backs every forklift with proven product support. Resources include factory-trained service technicians, Toyota Genuine Parts, and flexible leasing and financing packages through Toyota Industries Commercial Finance.

- ▶ Toyota forklifts have ranked No. 1 in safety and quality since 2002, according to studies conducted by Peerless Research Group.

For more information, including full specs, see your Toyota Dealer or ToyotaForklift.com.





HUPP
TOYOTAlift



Call your
local
Hupp
ToyotaLift
branch
for a
quote today!



CEDAR RAPIDS
319.362.0098 • 1.844.552.7216

DAVENPORT
563.322.3168 • 1.888.322.3168

ANKENY
515.965.5555 • 1.800.966.4877

WATERLOO
319.433.0029

PEORIA, IL
309.674.4877 • 1.877.751.4877

